

2010 14u Inter-City Tournament

Team listed first occupies 3rd base dugout. Home team determined by coin toss. All games must have a winner. ITB if necessary. Championship Game (Game 37) shall be played if the loser of Game 36 is from the Winner's Bracket (first loss in the tourney). Two umpires per game for Bracket and Championship play. Additional rules attached.

WINNER'S BRACKET

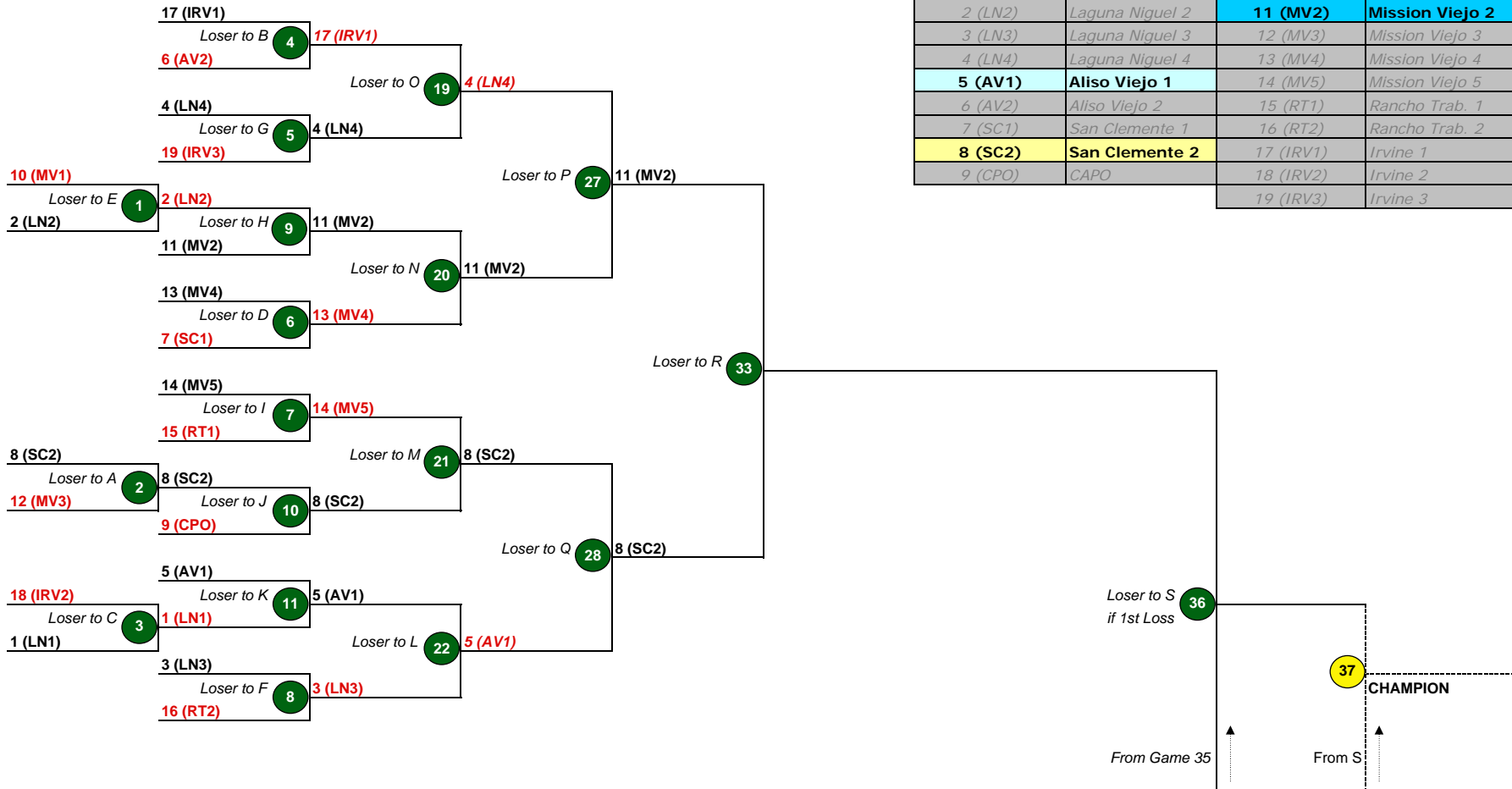

2010 14u Inter-City Tournament

Team listed first occupies 3rd base dugout. Home team determined by coin toss. All games must have a winner. ITB if necessary. Championship Game (Game 37) shall be played if the loser of Game 36 is from the Winner's Bracket (first loss in the tourney). Two umpires per game for Bracket and Championship play. Additional rules attached.

LOSER'S BRACKET

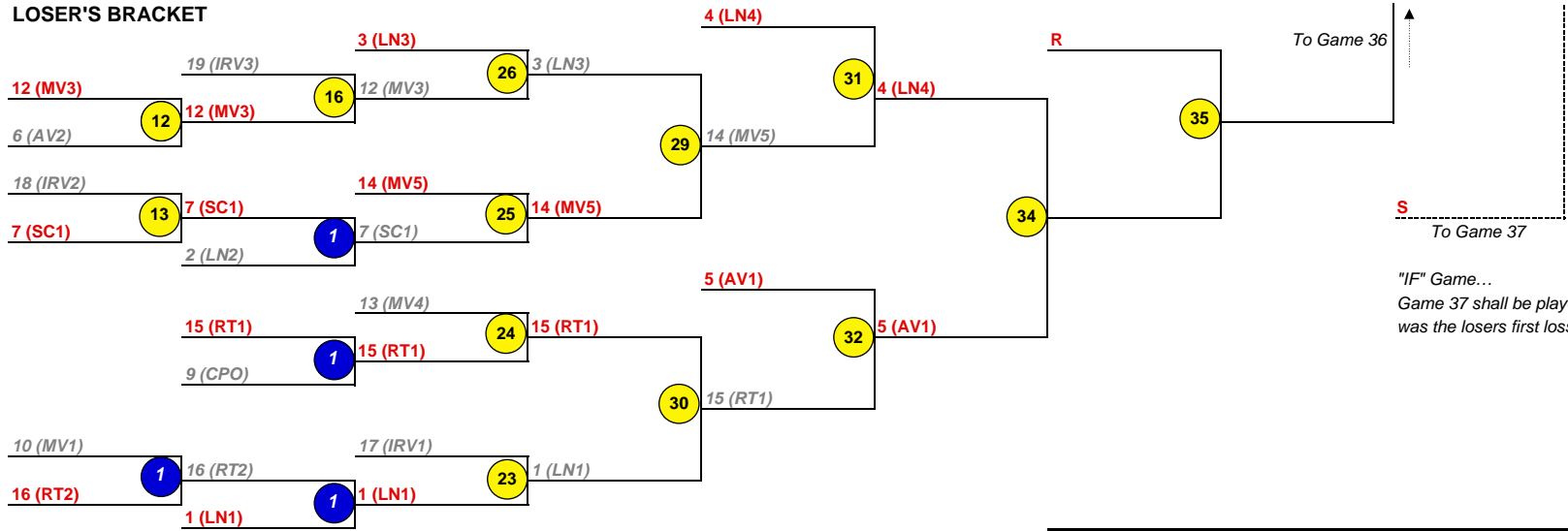

"IF" Game...
Game 37 shall be played if Game 36 was the losers first loss in the tourney.

14u Tourny	Location	Date	Time
Game 1	MV3	14-Apr	7:15 PM
Game 2	Steed (Y)	14-Apr	7:00 PM
Game 3	IRV-BB3	14-Apr	5:30 PM
Game 4	IRV-BB1	17-Apr	1:00 PM
Game 5	IRV-BB1	17-Apr	3:00 PM
Game 6	MV3	17-Apr	4:30 PM
Game 7	TM1	17-Apr	1:00 PM
Game 8	TM1	17-Apr	3:00 PM
Game 9	MV4	17-Apr	4:45 PM
Game 10	Cook 1	17-Apr	1:00 PM
Game 11	AVCP-1	17-Apr	1:00 PM
Game 12	NHMS F3	19-Apr	7:00 PM
Game 13	NHMS F5	19-Apr	7:00 PM
Rescheduled Game 14	NHMS F5	22-Apr	7:00 PM
Rescheduled Game 15	Gapo / Cooks	24-Apr	1:00 PM
Game 16	NHMS F5	21-Apr	5:00 PM
Rescheduled Game 17	San Clemente	25-Apr	4:00 PM
Rescheduled Game 18	NHMS F5	26-Apr	5:15 PM

Rescheduled
Rescheduled
Rescheduled
Rescheduled

Debbie L
Dave Kushner
Jack
Debbie L

14u Tourny	Location	Date	Time
Game 19	NHMS F5	24-Apr	10:00 AM
Game 20	NHMS F5	24-Apr	12:00 PM
Game 21	NHMS F5	24-Apr	2:00 PM
Game 22	NHMS F5	24-Apr	4:00 PM
Game 23	NHMS F5	27-Apr	7:00 PM
Game 24	NHMS F5	27-Apr	5:00 PM
Game 25	NHMS F5	28-Apr	7:00 PM
Game 26	NHMS F5	28-Apr	5:00 PM
Game 27	NHMS F5	1-May	4:00 PM
Game 28	NHMS F5	1-May	2:00 PM
Game 29	NHMS F5	1-May	12:00 PM
Game 30	NHMS F5	1-May	10:00 AM
Game 31	NHMS F5	4-May	5:00 PM
Game 32	NHMS F5	4-May	7:00 PM
Game 33	NHMS F5	5-May	5:00 PM
Game 34	NHMS F5	5-May	7:00 PM
Game 35	NHMS F5	6-May	5:30 PM
Game 36	NHMS F5	8-May	12:00 PM
Game 37 (IF game)	NHMS F5	8-May	2:00 PM

2010 14u Inter-City Tournament Rules

- 1 Team listed first (top) shall occupy 3rd base dugout. Coin toss to determine the "Home" team.
- 2 Home field ground rules, fair and foul, dead ball areas, and specific safety issues will be followed.
- 3 Round robin batting.
- 4 No new inning after 1:25, finish the inning. The game must produce a winner.
- 5 6 runs max for the first four (4) innings. Unlimited from the fifth inning on.
- 6 No player rotation required; unlimited pitching.
- 7 Courtesy runners (CR) for pitchers and catchers. The CR shall be the last out. Should no out be on the books yet, it shall be the batter scheduled to bat last in the inning.
- 8 Injured offensive players: You may use a CR for an injured player one time. The runner will be the last recorded out. After that, the player can be removed from the game without penalty.
- 9 Mercy: 15 after 3, 12 after 4, 8 after 5
- 10 Two umpires system: Each team shall pay an umpire \$35.00.
- 11 One minute or 5 pitches between innings.
- 12 A player arriving late can be added to the bottom of the batting order.
- 13 A player leaving early must check out with both score keepers, with no penalty.
- 14 Should a player not check out with the scorekeepers and a batting out of order occurs, ASA rules shall govern.
- 15 Only players that are rostered for each particular team may play.
- 16 Tie Breaker Rule: Should the game require a tie breaker; the player scheduled to bat last in the inning shall start the inning at 2nd base. No courtesy runners (CR) will be allowed.
- 17 One (1) substitution player is allowed only if a team can not produce 9 rostered players to start a game. The substitute player must play outfield and bat last. The substitute player must be an age appropriate player registered with the league she is substituting for.
- 18 Niguel Hills Middle School (LNGS) fields are on a shared facility with a school, which has a 'no dogs' policy from the city. No dogs at this facility please. Violators shall be ejected by the umpire.